

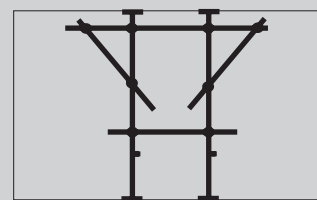

# Wall Spreader

The Wall Spreader is a telescopic spanning system which is able to withstand heavy loads. By spanning the Wall Spreader between two solid walls, the telescopic poles form an arch. This arch points upwards (similar to a bridge), allowing it to take considerable loads, e.g. lighting fixtures.

Der Wall Spreader ist ein Teleskopspannsystem zum Aufnehmen hoher Lasten. Durch Verspannen des Wall Spreader zwischen zwei festen Wänden bilden die Teleskopstangen einen Bogen. Der so entstandene, nach oben gerichtete Bogen (ähnlich dem Brückenbauprinzip), ermöglicht es, hohe Lasten wie z. B. Scheinwerfer - aufzunehmen.

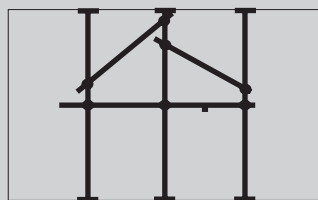
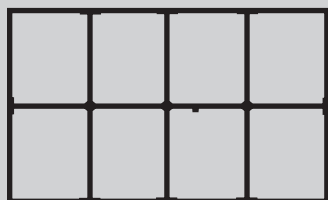
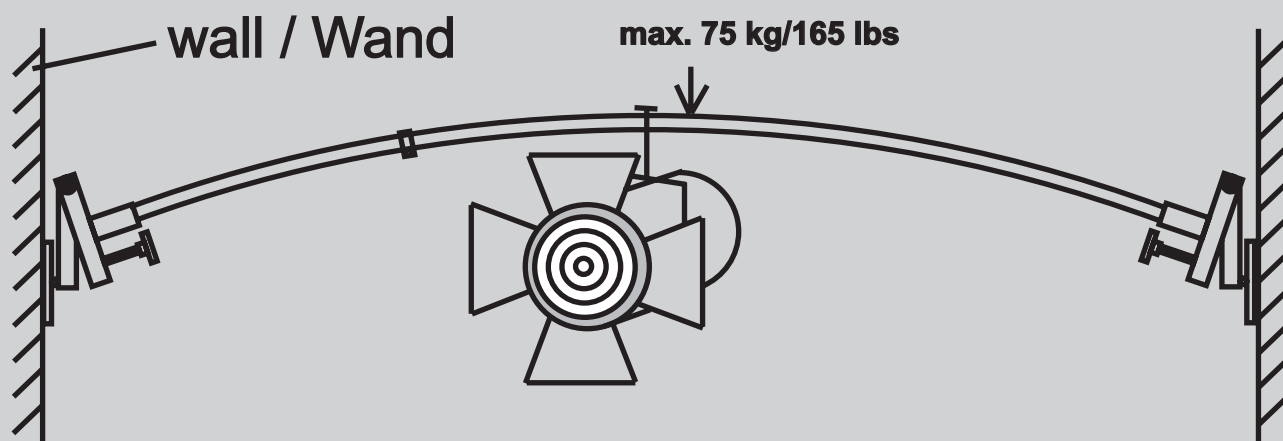

Various Wall Spreader set ups can be achieved.  
Verschiedene Wall Spreader Aufbauvarianten sind möglich.



Complete set existing of:

- 2 x telescopic pole 1,40 - 2,50 m (4.5 - 8ft.)
- 2 x telescopic pole 2,15 - 4,00 m (7 - 13ft.)
- 2 x telescopic pole 3,15 - 6,00 m (10 - 20ft.)
- 8 x tightening element
- 6 x clamping ring
- 4 x double clamping ring
- 4 x plastic tube
- 2 x extension-tube
- 4 x buffer
- 1 x clamping ring with euroadapter
  
- 1 x bag for poles
- 1 x case for components